

Make Your Home a Masterpiece.®



The Vista Series

by AMSCO Windows®



WHY CHOOSE VISTA?

The Vista has found the crossroads of energy efficiency and affordability. Triple pane options provide greater energy efficiency while the 2 5/8 inch frame maintains optimal viewing area. The contemporary design is sure to increase curb appeal and compliment your architectural design.



COLORS



The Vista offers three of the most popular colors available in vinyl windows. It is available in white, almond and taupe.

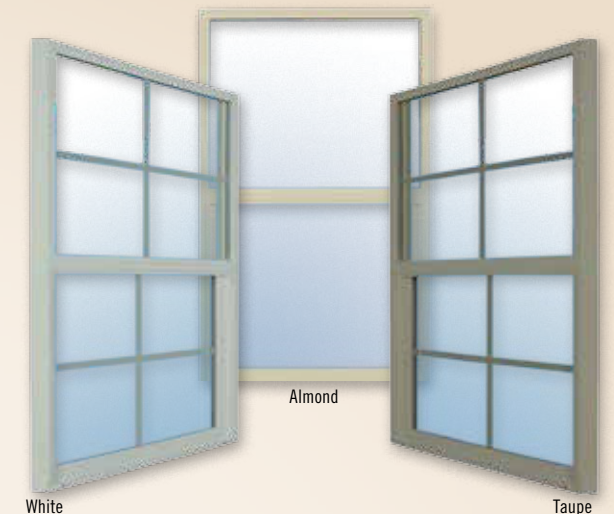

White

Almond

Taupe

White

Almond

Taupe

GRID OPTIONS

The Vista allows several grid options to add architectural interest and design elements both inside and out. Grids are available inside of the insulated unit in 5/8 inch flat, 3/4 inch sculptured and 13/16 inch flat grids.

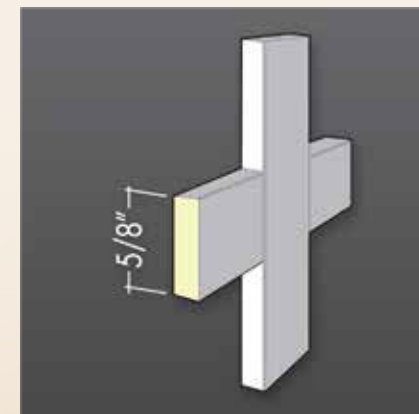

5/8 Inch
Flat Grid

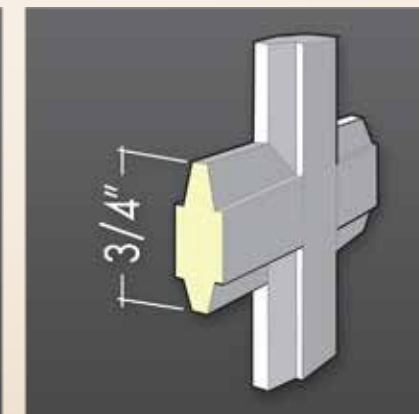

3/4 Inch
Sculptured Grid

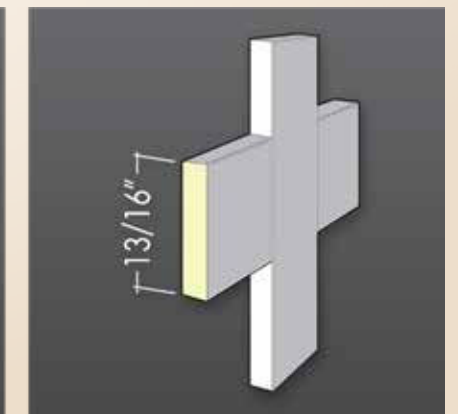

13/16 Inch
Flat Grid

QUALITY VINYL

Not all vinyl is created equal. Lesser quality vinyl can discolor and warp with exposure to sun and harsh UV light. AMSCO's unique, western-climate specific PVC formula is scientifically formulated to withstand even the harshest conditions season after season – all while maintaining its stability and function, without cracking, chipping, flaking or chalking.



GLASS OPTIONS

High performance, Energy efficient Glass Options protect your home from temperature extremes. All of our glass options feature warm edge spacer technology, which reduces thermal transfer and condensation.



AMSCO CōzE (Standard Low E Glass, Cardinal 270)

Standard on every Vista Series window.



AMSCO CōzE HV (Cardinal 366)

High energy performance rating, high visibility and significant UV protection.

Argon Gas

Can be added to any of our glass configurations to improve energy efficiency.

Brite

Glass designed to be easier to clean and to stay clean longer.



AMSCO CōzE Tint (Cardinal 240)

High energy performance rating, glare control, and tinted for a beautiful aesthetic appearance.



AMSCO Vantage Glass

Unique insulated glass unit designed to give you maximum performance in U value and SHGC by utilizing Hard Coat Low E technology. Low E is on two surfaces in this option.

Super Spacer IG units

Closed dense cell material for higher performance.



1 Inch Nail Fin Set-Back

Integral 1 inch nail fin setback, a common frame style for new construction applications.

3/4 or 7/8 inch Insulated Glass Unit

Choose from standard 3/4 inch or 7/8 inch insulated glass units to optimize your energy efficiency.



Standard Cam Lock

The standard cam lock is a classic, dependable, long lasting and easy to use option and comes standard on the Vista Series.



Continuous Frame Option

The continuous frame option allows you to join more than one window in a single frame thereby increasing structural integrity.

CERTIFIED QUALITY

Every AMSCO product meets or exceeds the criteria for a host of critical quality standards.



In addition to our own stringent quality control standards, AMSCO is a proud member of the National Fenestration Rating Council, the American Architectural Manufacturers Association and has earned the right to carry the Energy STAR label, a program sponsored by the Department of Energy. These organizations set the standards for the entire window and door industry.

AAMA Gold Labeled

All Vista Series windows and patio doors are tested and certified to both structural and water infiltration test requirements. (This is the highest standard in the industry and requires independent auditing for quality assurance)

PERFORMANCE DATA

| | U-VALUE* | SHGC** | VT*** | STC**** | STRUCTURAL RATING | MAXIMUM SIZE |
|------------------------------------|-------------|-------------|-------------|---------|-------------------|---------------|
| THE VISTA | | | | | | |
| SINGLE HUNG | 0.22 – 0.50 | 0.18 – 0.66 | 0.26 – 0.69 | 26 – 32 | R-PG25 | 48x84 |
| HORIZONTAL SLIDER | 0.22 – 0.50 | 0.18 – 0.65 | 0.26 – 0.66 | 26 – 32 | R-PG15 / R-PG20 | 72x72 / 72x60 |
| PICTURE WINDOW (DIRECT SET) | 0.16 – 0.49 | 0.19 – 0.71 | 0.28 – 0.75 | 27 – 33 | CW-PG35 | 96x72 |

*U-Value represents the amount of heat transfer as measured in accordance with NFRC 100.

**Solar Heat Gain Coefficient (SHGC) measures the amount of solar radiation entering the building as measured per NFRC 200.

***Visible Transmittance (VT) measures the amount of visible light through the overall unit.

NOTE: Data shown is for comparison purposes only and is accurate as of September 1, 2016. Performance data is for overall window units and not glass only. Data presented is a range based on (SS annealed glass, dual pane 3/4" IG, CōzE, without grids, Intercept spacer with air fill) to (DS annealed glass, dual pane 3/4" IG, CōzE HV, without grids, Cardinal spacer with argon fill). Other options may affect performance values including values that may be outside of the ranges shown here. Please contact your Authorized AMSCO Dealer for actual values of units. All values are certified through AAMA or NFRC.

ABOUT US

AMSCO Windows is a privately held company founded in 1949. Our 535,000 square foot manufacturing plant is located in Salt Lake City, Utah.

Many of AMSCO's employees have helped to grow the company over decades of service to AMSCO. This stable work environment provides for quality, long-term stability and a company you can count on now and into the future.

AMSCO has an on-site tempering furnace, multiple insulated glass lines and state-of-the-art equipment to assure a consistent and efficient manufacturing process.

AMSCO tempering furnace



THE AMSCO GUARANTEE

Simply put, we back our windows with a warranty that gives you peace of mind. Our Limited Lifetime Warranty covers any defects in materials or workmanship in our vinyl windows and doors for as long as you own your home. Our warranty process is administered by your local dealer to ensure your satisfaction. See your authorized AMSCO dealer or visit us online at www.amscowindows.com for complete warranty details.





Make Your Home a Masterpiece.®

AMSCO Windows

1880 South 1045 West 801.978.5000 TELEPHONE
PO Box 25368 801.974.0498 FACSIMILE
Salt Lake City, Utah 84125 800.748.4661 TOLL FREE

amscowindows.com



Copyright © 2016 AMSCO Windows. All rights reserved.
Brite, CōzE, Make Your Home a Masterpiece, AMSCO and AMSCO Windows are registered trademarks of AMSCO Windows. ENERGY STAR and the ENERGY STAR mark are registered U.S. marks. All other registered and unregistered trademarks herein are the sole property of their respective owners.